

(The Golden Peacock Group)



Wire Rope Suspension Solutions



www.gpltechnicalsolutions.com

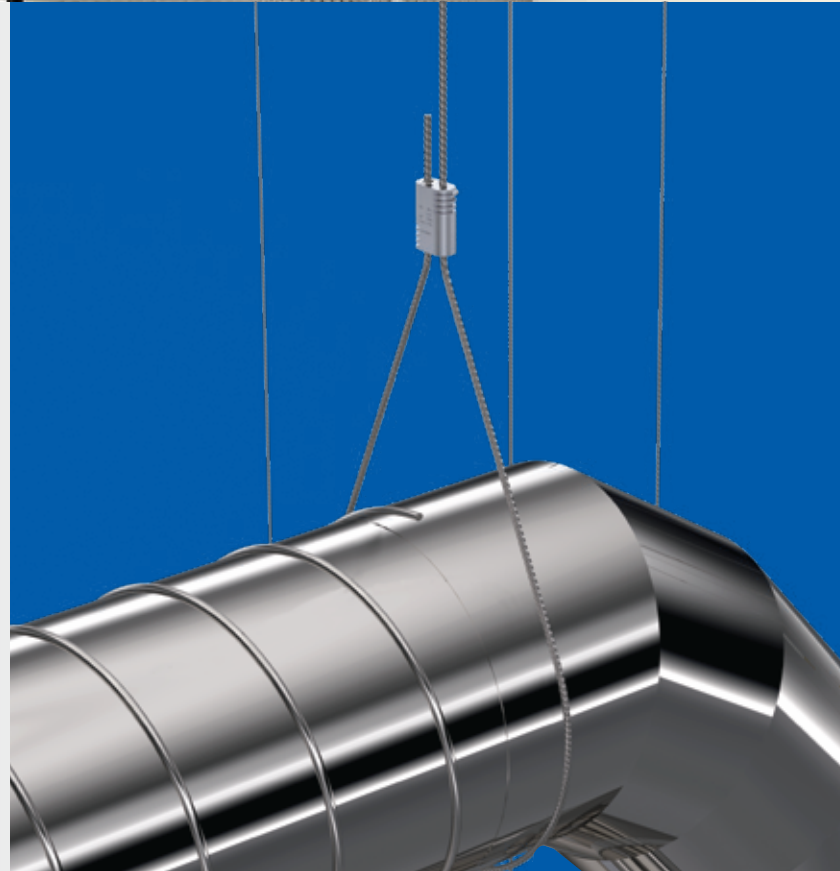

Who we are

Golden Peacock Group started operations in 1948. Since then, engraving its mark worldwide in manufacturing wire Rope Suspension Systems, Heavy duty grippers for rigging & industrial applications, Railing components, Seismic components, Decorative Lighting Components, Précised Turning parts, Sheet Metal products, Extruded parts, and Die Casting components.

GPL head office is established in the Free trade zone in the proximity of Delhi, India having a state-of-the-art production facility spread over 200,000 sq. ft at strategically located manufacturing plants in Noida (U.P) and Jamnagar (Gujarat) – Well connected with Rail, Road, and Air.

We have 20+ patents across the globe & we offer a wide product line that is manufactured by adhering to the international quality parameters, non- polluting norms and using the best quality raw material to gain optimal durability. The right combination of experience, production techniques and machines assist us in making result-oriented & acceptable products, available in different sizes as per the specifications of clients.



GPL Strengths:

- GPL production facility processes different metals and offers diversified product ranges for multiple application.
- We have got in-house research and design team, which helps us in innovating new products, understand customer custom-made requirements, and bring in cost effective design solution.
- Quality consciousness is an inbuilt feature in the organization where our team is trained to manufacture the right product in the process.
- Well-equipped quality lab with qualified & trained personnel, who ensures quality as per international standards.
- Vertically integrated manufacturing set up to offer complete wire rope suspension systems under one roof.
- Situated in Noida Special Economic Zone, which helps to get the shipments/containers inspected and secured by Indian customs at our doorstep. This avoids loss & damage of goods during transit. We also avail duty free import facility for our raw materials.
- We are ISO 9001:2015, CE, UL, RoHS, IMG, BSI, NEMCO, and Reach complaint factory.

Certifications

CERTIFICATE OF COMPLIANCE

Certificate Number: UL-CA-2146728-0
Report Reference: E513046-20211112
Date: 9-Dec-2021

Issued to: GOLDEN PEACOCK OVERSEAS LTD
 Plot 20-A
 Nepe Noida, Uttar Pradesh
 India 201305

This is to certify that representative samples of DWMU7 - Conduit and Cable Hardware Certified for Canada
 See Addendum Page for Product Designation(s).

Have been investigated by UL in accordance with the Standard(s) indicated on this Certificate.

Standard(s) for Safety: CSA C22.2 NO. 18.4-15, 2nd Ed., Issue Date: 2015-02-01, Revision Date: 2019-03-22

Additional Information: See the UL Online Certifications Directory at <https://ul.ulprospector.com> for additional information

This Certificate of Compliance does not provide authorization to apply the UL Mark. Only the UL Follow-Up Services Procedure provides authorization to apply the UL Mark.
 Only those products bearing the UL Mark should be considered as being UL Certified and covered under UL's Follow-Up Services.
 Look for the UL Certification Mark on the product.



CERTIFICATE OF COMPLIANCE

Certificate Number: UL-US-2155524-0
Report Reference: E513046-20211112
Date: 9-Dec-2021

Issued to: GOLDEN PEACOCK OVERSEAS LTD
 Plot 20-A
 Nepe Noida, Uttar Pradesh
 India 201305

This is to certify that representative samples of DWMU - Conduit and Cable Hardware
 See Addendum Page for Product Designation(s).

Have been investigated by UL in accordance with the Standard(s) indicated on this Certificate.

Standard(s) for Safety: UL 2239, 2nd Ed., Issue Date: 2015-02-20, Revision Date: 2019-03-22

Additional Information: See the UL Online Certifications Directory at <https://ul.ulprospector.com> for additional information

This Certificate of Compliance does not provide authorization to apply the UL Mark. Only the UL Follow-Up Services Procedure provides authorization to apply the UL Mark.
 Only those products bearing the UL Mark should be considered as being UL Certified and covered under UL's Follow-Up Services.
 Look for the UL Certification Mark on the product.



WITNESS TEST REPORT



WITNESS TEST REPORT

Test Report No.: TUVPLASQCH17-160001-1
Page 1 of 8
Issue date: 24.03.2018

Manufacturer Name & Address: Golden Peacock Overseas Ltd, Plot 20A, Noida, Uttar Pradesh 201305

EU/ET Description: GPL Wire Suspension Kit

Trademark:    Serial No. : --

Sample No.: 01 GPL Cable Bracket (PCB) 200, 02 Threaded Steel Clamp with 1 Screw 03 Steel Wire, 04 Spring 05 Plain Washer
 06 GPL Cable Bracket (PCB) 200, 07 Threaded Steel Clamp with 2 Screws 08 Steel Wire, 09 Spring, 10 Plain Washer
 11 GPL Cable Bracket (PCB) 200, 12 Spring 13 Threaded Steel Clamp with 1 Screw 14 Steel Wire, 15 Spring 16 Plain Washer
 17 GPL Cable Bracket (PCB) 200, 18 Spring 19 Threaded Steel Clamp with 1 Screw 20 Steel Wire, 21 Spring 22 Plain Washer
 23 GPL Cable Bracket (PCB) 200, 24 Spring 25 Threaded Steel Clamp with 1 Screw 26 Steel Wire, 27 Spring 28 Plain Washer

Date of receipt: 2017-2018

Condition of sample at receipt: Good

Witnessing Laboratory/Institute with Address: Golden Peacock Overseas Ltd, Plot 20A, Noida, Uttar Pradesh 201305

Witnessing Agency Name & Address: TÜV India Pvt Ltd, 1st Floor, 201/202, B-3, Sector 7, Noida, Uttar Pradesh 110006

Test specification: AS/NZS 5063.1, IEC 60332 and Common Specifications

Test Result: Pass (See page 06, 07)

Other Aspects: The Report consists of 8 pages including this cover page.

This test report issues in the test sample submitted and list of documents attached

Witnessed & Prepared by:	Approved by:	Issued by:
		
Name / Addl. Name / Designation : Engineer	Name / Addl. Name / Designation: Head Lab Operations	Name / Addl. Name / Designation: Officer Customer Relations
Date: 24.03.2018	Date: 27/03/2018	Date: 24.03.2018

Registration & Head Office: 97/1, Ring Road, Phase - 1, L.B.S. Marg, Ghaziabad (UP), Mumbai 400 088.
 Phone : (022) 8847 7300 / Fax: (022) 8857 7302 / E-mail: [Mumbai@tuv-india.com](mailto: Mumbai@tuv-india.com) / Website: www.tuv-india.com
 *In certain version

TEST REPORT



Test Report No. GGN/H(M)/24/001470
Dated: 2024.07.05

Applicant / Company Name: Golden Peacock Overseas LTD
Address: 20A, Noida, Phase-02, Noida
Attention / Contact Person: Karan Singh
Tested Sample: Received on 2024.05.31 at 10:54 A.M.
Test Period: 2024.05.31 To 2024.06.07 (*)
Article / Sample Description: HVAC Suspension Kits
Material: Brass/Steel/Aluminum
Product Type / End Use: Suspension
Style No.: Suspension Kits - 1.5mm to 3mm
Supplier: Golden Peacock Overseas Ltd.
Country of Origin: India
Country of Destination: India

Notes: This certificate complies to IEC 60332-1 and IEC 60332-2.
 (*) Test was subcontracted to another laboratory.
 (**) Report has been released after received additional information.

Authorized By: 

Attest Attestant (Authorized Signatory):

Dissemination: For any technical issues: Anuradha Dhamija at Anuradha.Dhamija@tuvindia.com
 For any complaint: Ashima Sagar at Ashima.Sagar@tuvindia.com

By signing this document, the customer hereby agrees and accepts the Terms & Conditions and the relevant Witnessing & Certification Procedures of TÜV SÜD South Asia Pvt Ltd, which are available at company's website at the link: <https://www.tuv-india.com/terms-conditions>
 Here, the test report is issued in electronic form. Original signature is not required.
 Note: This report is valid only for the items tested. (2) The test report will not be reissued except in full without the written approval of the laboratory. (3) Any use of the test report for other purposes than for which it was issued is not allowed. This report is the result of a single examination of the sample in question and is not generally applicable. (4) The laboratory is not responsible for the quality of other products in regular production. For further details, please refer to the certificate of test results, chapter 4.4. (5) The acceptance of the information stated in this report is the responsibility of the customer's representative in the customer's responsibility. This laboratory reports the test information at the test report and a test label for the same. (6) The testing conditions are indicated on the respective test standard. (7) All other test conditions apply from the respective test standard unless otherwise specified for the test.
 TÜV SÜD South Asia Pvt Ltd, Ring Road, Phase - 1, L.B.S. Marg, Ghaziabad (UP), Mumbai 400 088.
 Phone : (022) 8847 7300 / Fax: (022) 8857 7302 / E-mail: [Mumbai@tuv-india.com](mailto: Mumbai@tuv-india.com) / Website: www.tuv-india.com
 *In certain version

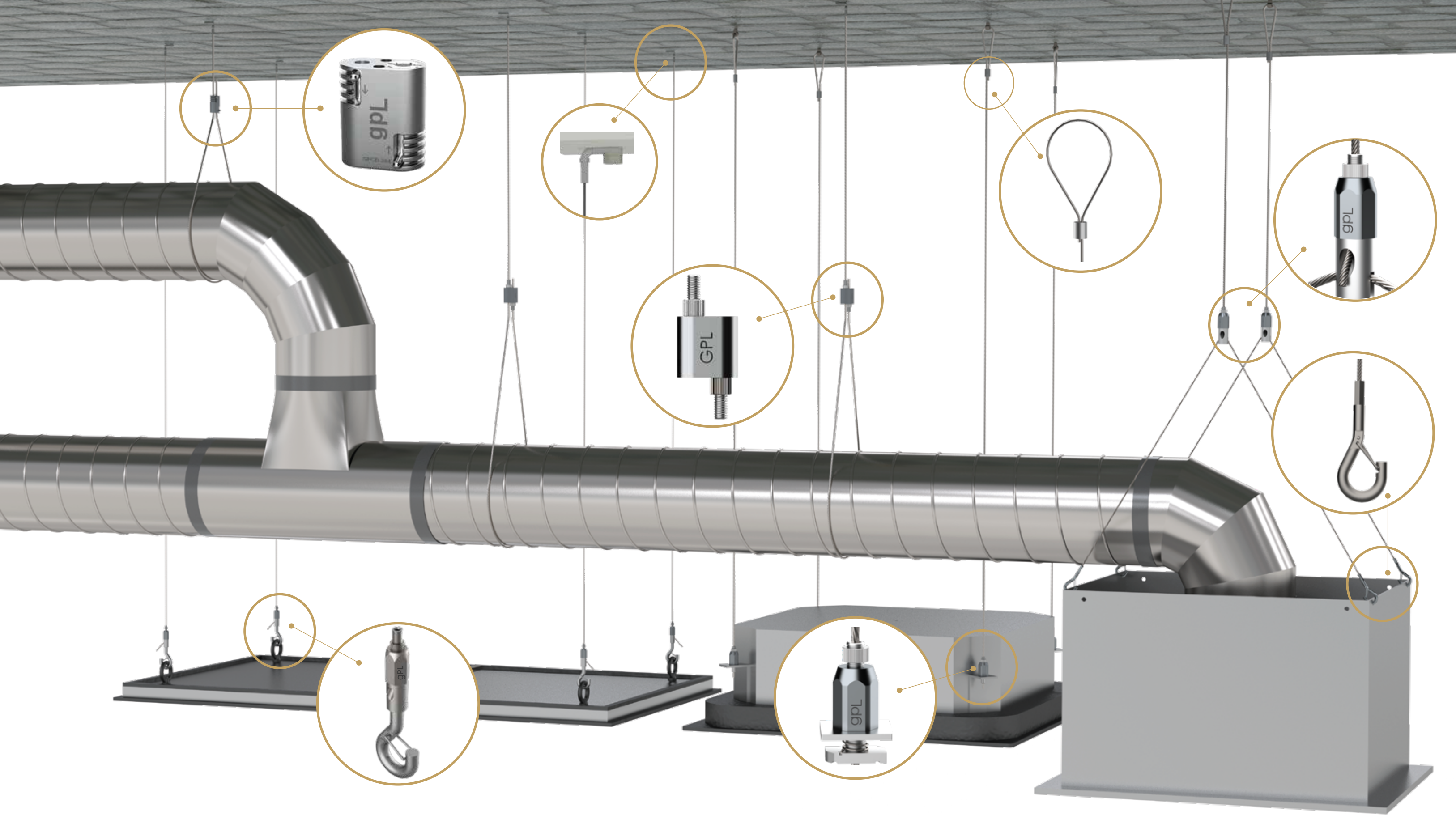

HVAC SOLUTIONS

Golden Peacock is one of the world's leading manufacturer of wire rope suspension systems. We offer complete solutions to suspend static load by offering 3 ball and 6 ball bearing locking mechanism in different materials along with wire ropes in Various thicknesses and end attachments.

Golden Peacock Wire rope suspension (GPWS) is increasingly being used for mounting building services components in commercial, public sector and industrial buildings. GPWS is a safe and reliable solution and is tested independently by TUV, UL and comply with SMACNA standards.

There are major advantages of flexible positioning and installation productivity benefits compared to traditional systems. GPWS helps adopting eco-friendly approach by drastically reducing the steel consumption & reducing carbon footprints due to ease of logistics.

GPWS can be used to support a wide range of loads and objects. Almost any piece of building services equipment could be suspended using wire ropes, such as:

- Pipe work
- Duct work
- Cable trays
- Ceiling grids
- Luminaires and lighting systems
- Large signs and indicator display
- Decorative objects
- Fan coils and air handling units

Advantages of GPWS

- Aesthetically pleasing & Lightweight products.
- Easy to adjust without special tools, making it hassle free installation.
- Faster to install compared to threaded rods, save time and money.
- Less storage space required.
- Easy to handle & transport at site.
- Can easily be installed at an angle, serves multiple applications.
- Offers 5:1 safety feature for vertical plane.
- Offers different sizes to carry specific weight range for different applications.
- Optional locknuts are available for superior safety to avoid damage due to accidental movement/ seismic vibration.

Gripper

A Gripper is a sophisticated piece of hardware that allows the user to adjust the height of a fixture without utilizing tools. As a cable slides through the gripper, a plunger and three balls within the gripper surrounds the outside diameter and catches the cable as it passes through the gripper. When mounted and weight is applied to the gripper, the tension forces the balls to grab the cable in a pinching movement.

The use of six balls offers a maximum safe working load by gripping the wire at six points. Balls have the advantage of rolling instead of sliding which makes it easier for the mechanism to grip the wire. It is a limitation of serrated wedge grippers that the wedge needs to slide under high loads and can sometimes stick in the passage of the gripper and it becomes difficult to release the wedge through its actuating pin, by hand, in order to release the cable.

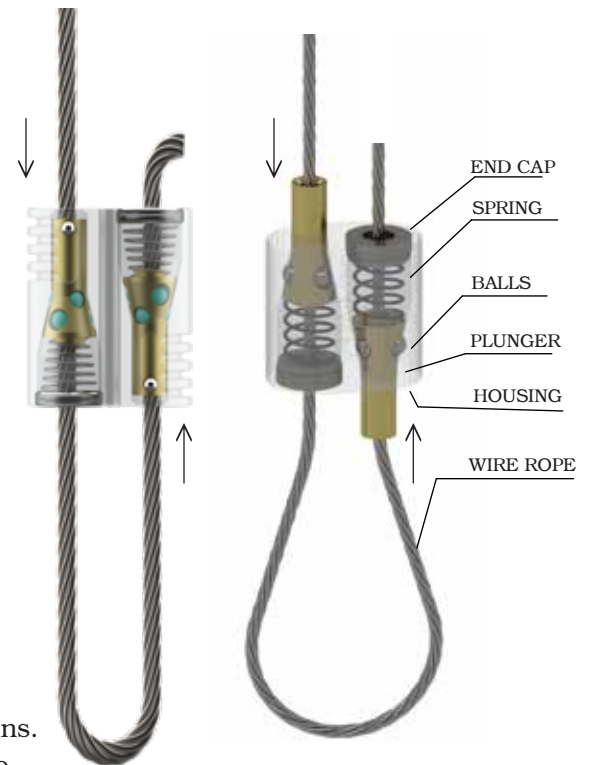

Loop Grippers

GPWS loop grippers are unique ball-bearing, tool less wire gripping devices.

These are available in different sizes and all of them are designed specifically for suspending different loads for a variety of applications.

GPWS introduced Aluminium loop gripper which are one of the most environment friendly metals because of its sustainability. As the most recyclable industrial material, aluminium can be recycled infinitely to produce the same product without degrading its inherent value. Recycling aluminium also saves 95% of the energy used in its production from raw materials.

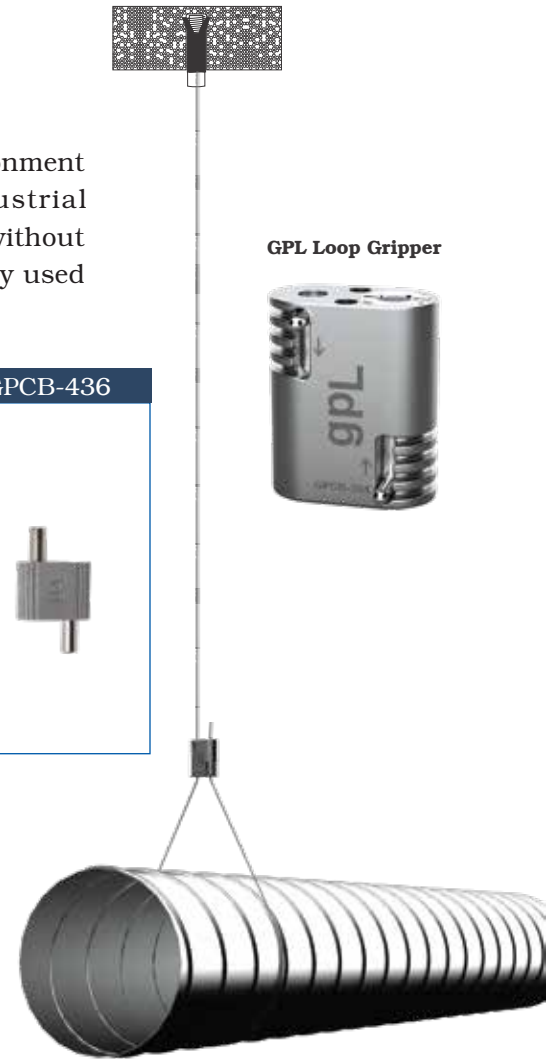
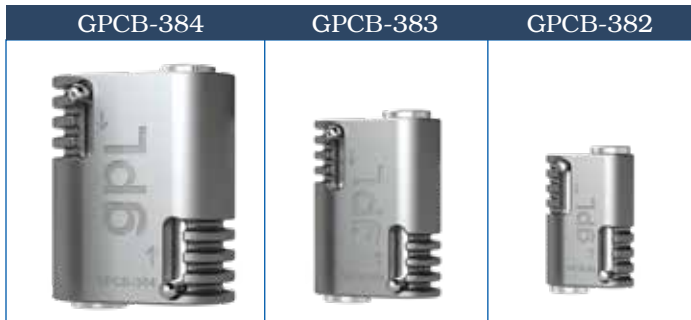
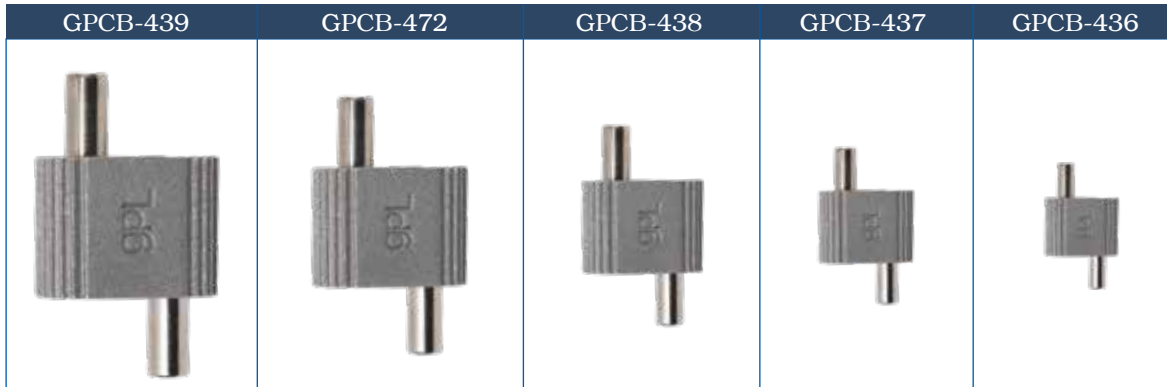

Technical Information (Load Ratings)

Product Code	Wire Range	Safety Factor	Safe Working Load (Kg)
GPCB - 436	1.5 mm	5:1	Up to 30
GPCB - 437	2.0 mm	5:1	Up to 50
GPCB - 382	2.0 mm	5:1	Up to 50
GPCB - 438	3.2 mm	5:1	Up to 113
GPCB - 383	3.2 mm	5:1	Up to 113
GPCB - 472	4.0 mm	5:1	Up to 160
GPCB - 439	5.0 mm	5:1	Up to 300
GPCB - 384	5.0 mm	5:1	Up to 300

HEXA Grippers

Description:

The GPL Hexa gripper assembly stands as a rapid and reliable solution for efficiently placing Strut in single or multi-tiered setups, catering to both HVAC and cable management requirements. Tailored to support the suspension of rectangular ducts, cable trays, unit heaters, and more, it offers a flexible approach. Installation is made more convenient by the option to pre-install the assembly into the strut channel at ground level, minimizing high-altitude work time. Additionally, its threaded piston streamlines height adjustments, ensuring a timesaving benefit.



Ideal for below Applications but are not limited to:

1. Electrical
2. HVAC & Mechanical
3. Single-tier cable tray suspension
4. Multi-tier cable tray suspension

Features:

1. GPL Hexa grippers are made up of aluminum material which is a lightweight & strong structural material.
2. Versatile – GPL hexa range can be used with different applications.
3. Safe, durable, Quick & easy to install.
4. Come with a lock nut for extra safety.
5. Can be used with single or multi-tier applications.
6. Ideal for static loads
7. Safety factor – 5:1 ratio

Hexa Gripper Details

Series Code	Wire Size	Standard	Bottom Exit with Loop	Bottom Exit with Channel Nut	Side Exit with Y-FIT	Side Exit with tail	Side Exit with Fork
GPCB - 394	2.0 mm/5-64 inch	✓	✓	✓	✓	✓	✓
GPCB - 394	2.40 mm/3-32 inch	✓	✓	✓	✓	✓	✓
GPCB - 420	3.20 mm/1-8 inch	✓	✓	✓	✓	✓	✓

Hexa Gripper Product Range

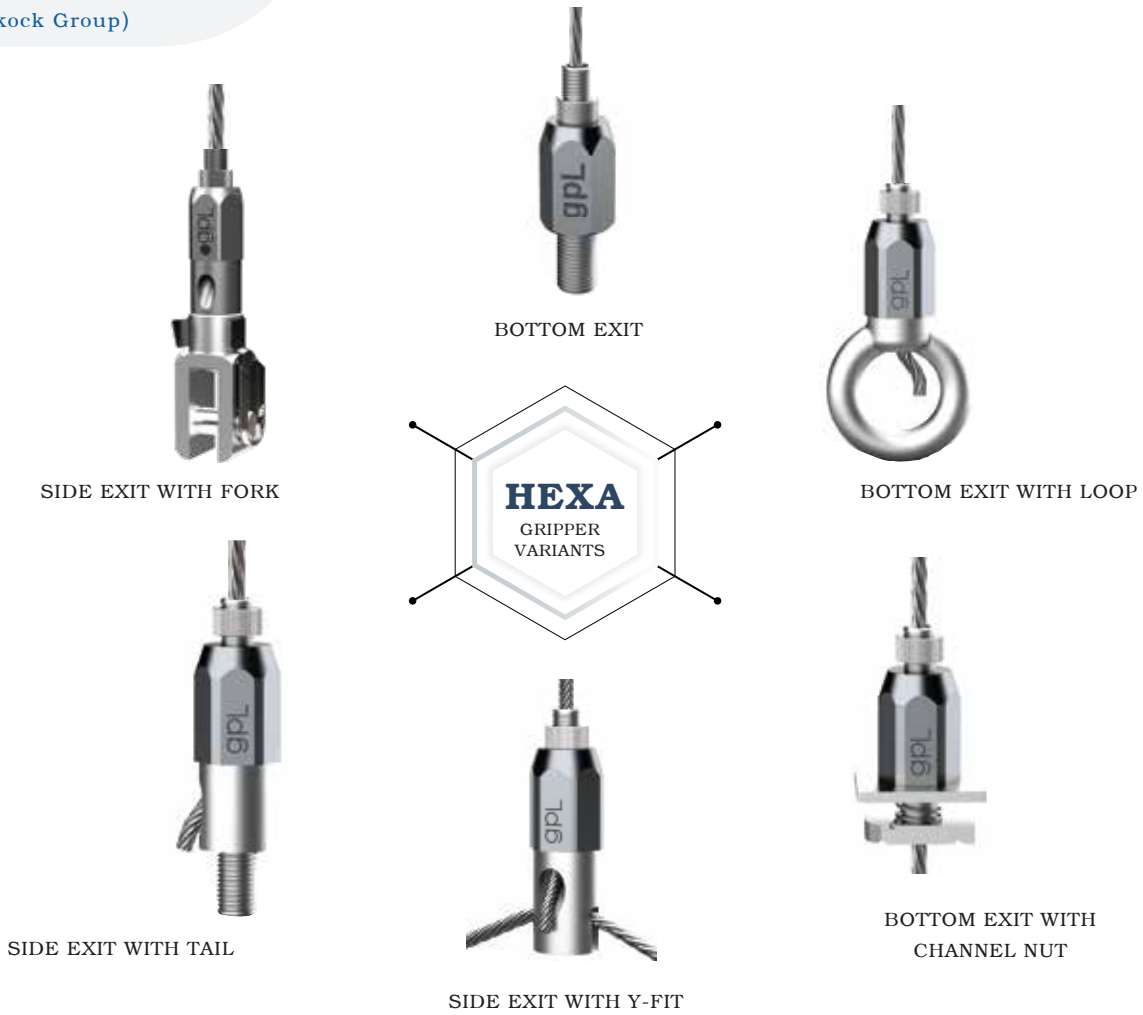

Wire detail and breaking strength

Wire Diameter	Series Code	Wire Construction	Wire Material	Safe Working Load of Wire	Breaking Load of Wire
2.0 mm/5-64 inch	GPCB - 394	7x7	Galvanized Steel	45kg/ 100lbs	225kg/495lbs
2.4 mm/3-32 inch	GPCB - 394	7x7	Galvanized Steel	60kg/132lbs	300kg/660lbs
3.2 mm/1-8 inch	GPCB - 420	7x7	Galvanized Steel	100kg/220lbs	500kg/1100lbs

Note: The correct gripper and wire rope combination should be used to ensure desired minimum safe working loads.

Hexa Gripper Assembly

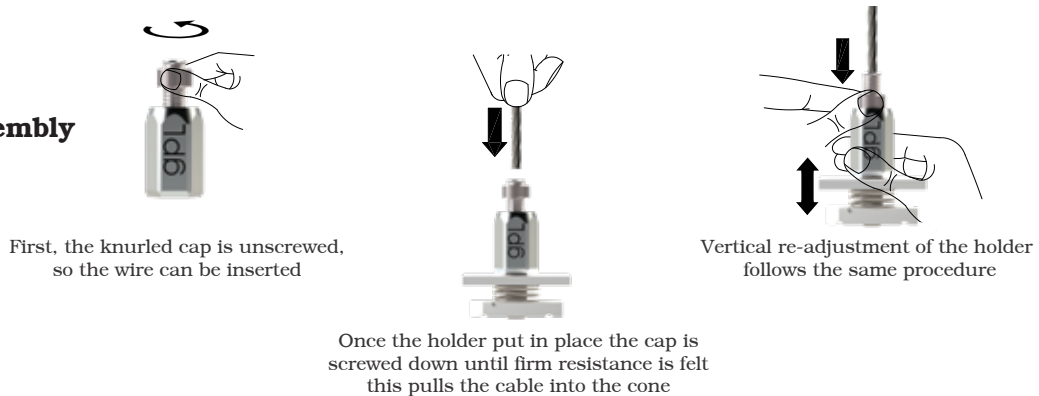

The GPL seismic cable bracing solution is a set of cables strategically placed within a structure to provide additional lateral support. These cables are tensioned and anchored to key structural components, working together to absorb and distribute seismic forces. It is used as a bracing system for suspended nonstructural components, equipment and systems. This system is particularly effective in tall or expansive structures, where the magnitude of lateral movement during an earthquake can be substantial.



Features & Benefits

- Kit includes pre-attached swivel eyelet with wire assembly, loop gripper & bracket.
- Available in different wire lengths for 3, 5, 10mtr.
- Color tags for easy identification of cable size & load bearing capacity.
- The Safe load carrying capacity of each kit is determined as per IS 800 (2007).
- The equivalent standards are AISC 360 (2010), EN 1993 Eurocode 3, and NZS 3404 (1997)
- Save up to 50% on installation time and 10 times faster than traditional methods.
- Perfect for new or retrofit applications.
- Light weighted kit, easy to carry on the job site.

General Principles

GPL bracing solution system must be designed by a qualified structural engineers to ensure that when installed correctly they comply with the relevant standards.

- A pair of cables opposing each other are always required to brace a component, as loads are dynamic and cyclical.
- Cables should not touch any object along their length.
- Brace angles from the horizontal must not exceed 60°.
- Anchor points must be correctly qualified for the earthquake load demand, whether fixing to concrete, steel or timber.
- Anchor brackets must be loaded in line with the cable to prevent excessive prying of the anchors.
- The cables of a 4-way brace must directly oppose each other.

Installation

- Attach Seismic Anchor Bracket to ceiling structure with appropriate anchor as per manufacturer's instructions, following qualified Structural Engineer's recommendations/calculations.
- Fit Anchor bracket to existing primary supports at designated locations, ensuring bracket orientation is correct.
- Pass wire rope through GPL seismic locking device.
- The Loop wire through available hole in the bracket and position wire against through hole.
- Feed wire back into GPL seismic locking device & tighten the lock for extra safety.
- Apply tension.
- Coil excess wire and secure to main brace if necessary trim excess wire leaving 150mm tail.

Seismic Cable kit includes:

- Pre-stretched wire in different dia. - 2.0, 3.2, 5.0, mm
- Pre-attached Swivel eyelet
- Standard bracket & retrofit bracket
- Aluminum loop cable blocker with lock nut
- Color coded tags - GPL seismic bracing system are color coded to allow easy field verification of cable diameter, each color representing a different load bearing capacity.



Cable Gripper with Locknut



Standard & Retrofit Bracket



Swivel Eyelet



Pre-Stretched Wire

Safe load capacity of seismic bracing solution

GPL Seismic kit	Cable Diameter	Components of the system	Label Colour	Cable Orientation angle (Horizontal)	Allowable Strength design (ASD) (KG)	Maximum Design strength (LRFD) (KG/ LBS)
GPL-S-382	2.0mm/ 5-64"		Green	30°	101/ 223 kg lbs	151/ 333 kg lbs
			Green	45°	152/ 335 kg lbs	228/ 503 kg lbs
			Green	60°	232/ 511 kg lbs	348/ 767 kg lbs
GPL-S-383	3.0mm/ 1-8"		Yellow	30°	215/ 474 kg lbs	322/ 710 kg lbs
			Yellow	45°	323/ 712 kg lbs	484/ 1067 kg lbs
			Yellow	60°	503/ 1109 kg lbs	754/ 1662 kg lbs
GPL-S-384	5.0mm/ 3-16"		Blue	30°	697/ 1537 kg lbs	1045/ 2304 kg lbs
			Blue	45°	1008/ 2222 kg lbs	1512/ 3333 kg lbs
			Blue	60°	1178/ 2597 kg lbs	1767/ 3896 kg lbs

Duct Corner Hanger

Specifications, Features & Advantages:

The GPL Duct Corner Hanger is a fast and easy self-locking / adjustable / secure solution for suspending a rectangular duct and similar application. It is the perfect alternative to the traditional method of suspending ductwork. There is a special feature of wire adjustment via Static Pull mechanism system, which ensures safety & ease of installation.



Wire rope detail and breaking strength

Wire Diameter	Construction	Material	Safe Factor	Breaking Load
2.0mm/5-64 in	7x7	Galvanized Steel	45kg/100lbs	225kg/495lbs
3.2mm/1-8 in	7x7	Galvanized Steel	100kg/220lbs	500kg/1100lbs

Note: The correct gripper and wire rope combination should be used to ensure desired minimum safe working loads.

Assembly Instructions



1st step - Attach the duct corner hanger to bottom corners of duct with self-drilling screws (Not provided by GPL). Three fixing screws required for one hanger. Please ensure the rubber pad should be available with all hangers because it prevents air leakage & vibrations. The above process to be done at floor level.



2nd step - Once the duct corner hangers are fixed with duct, insert the wire in hanger and then pull the wire to test the gripping.



3rd step - After the wire fitting with the hanger, we can hang the ductwork system with a suspension system. At least 100mm wire should reflect from bottom side of hanger as a tail to allow the future adjustment.



4th step - If need to re-adjust the placement, then pull the circlip of beam clamp to wire adjustment and release.

Beam Clamp Cable Gripper

Specifications, Features & Advantages:

The GPL Beam Clamp Cable Gripper is a fast and easy self-locking / adjustable solution for suspending an object from an overhead structure by means of cables. It is the perfect alternative to the traditional method of suspension system, which is used after installation of a beam. There is a special feature of wire adjustment via Pull mechanism, which ensures safety & ease of installation.

Features -

- Easy & fast installation
- Cable gripper mechanism
- No punching required
- Firmly installed
- Zinc plated for corrosion resistant

Wire rope detail and breaking strength

Wire Diameter	Construction	Material	Safe Factor	Breaking Load
2.5mm/3-32 in	7x7	Galvanized Steel	50kg/110lbs	250kg/550lbs
4.0mm/5-32 in	7x7	Galvanized Steel	120kg/264lbs	600kg/1100lbs

Note: The correct gripper and wire rope combination should be used to ensure desired minimum safe working loads.



Assembly Instructions

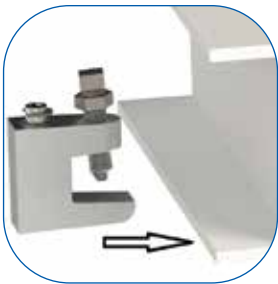

1st step - Unscrew the square bolt of beam clamp to few threads and fit it with beam and tighten the square bolt & hex nut to fix it.



2nd step - Once the beam clamp is fixed with beam, insert the wire in beam clamp and then pull the wire to test the gripping.



3rd step - After the gripping test, we can hang the object with wire.



4th step - If need to re-adjust the placement, then pull the circlip of beam clamp to wire adjustment and release.

Catenary Hanger System

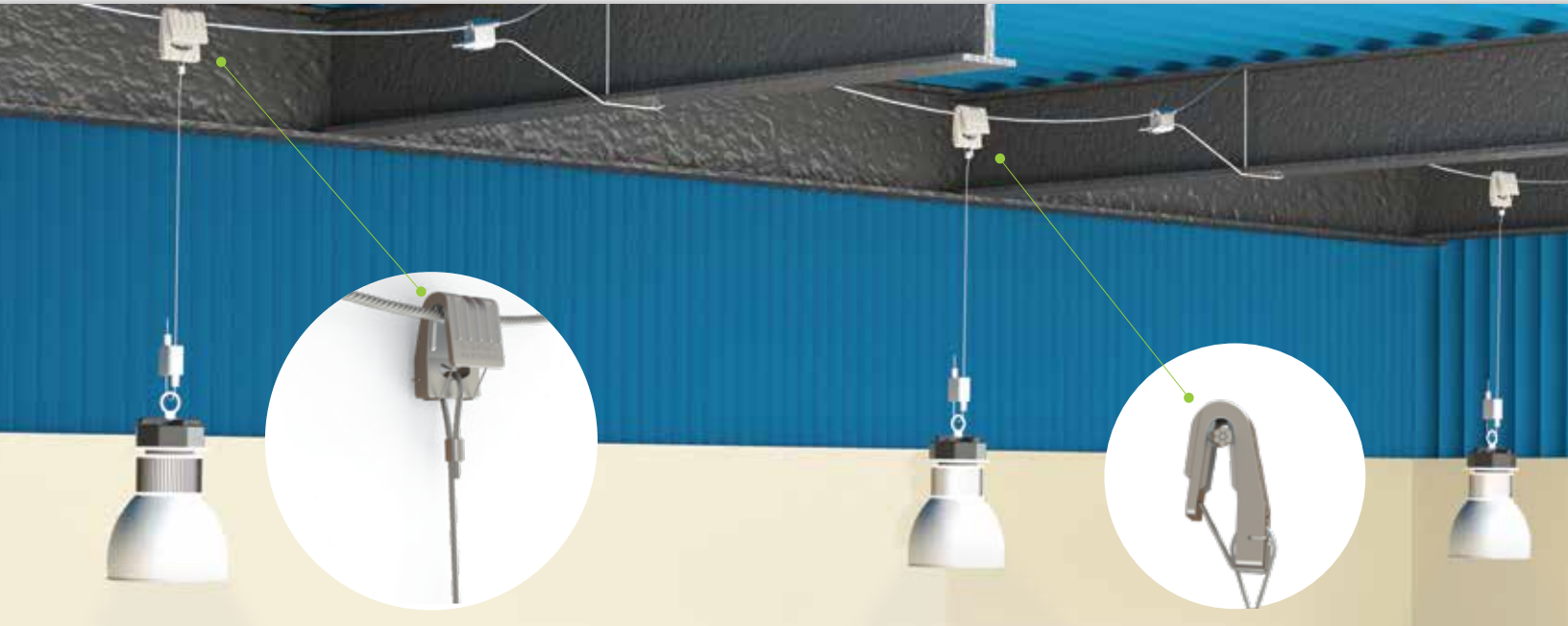

The GPL Catenary hanger is a specialized component which is ideal for use in settings without accessible overhead mounting options. This system is commonly employed in HVAC, MEP other Heavy-duty fixtures.

Features:

1. Easy & faster to install.
2. Multifunctional applications for HVAC, MEP, Lighting fixtures etc.
3. Easy to carry on site.
4. Designed for scenarios where there are no overhead anchor points.
5. GPL catenary hanger can use with three different wire dia. 4.0, 5.0, 6.35mm.

Model-no.	Material	SWL Per Free span <small>* Safety factory - 5:1</small>	SWL for bottom wire <small>* Safety factory - 5:1</small>
GPA-151	Aluminium	4.0mm wire - 40kg max.	1.5mm wire - 30kg max.
		5.0mm wire - 70kg max.	2.0mm wire - 50kg max.
		6.35mm wire - 100kg max.	3.0mm wire - 100kg max.

Catenary Installation

Special engineering grade casted material provides high strength and consistent quality. Hook is the main part of hanging & horizontal adjustment.

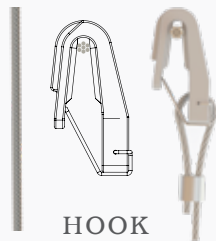

Special engineering grade spring system, it bounds the hanger to come out from horizontal tensioned wire.

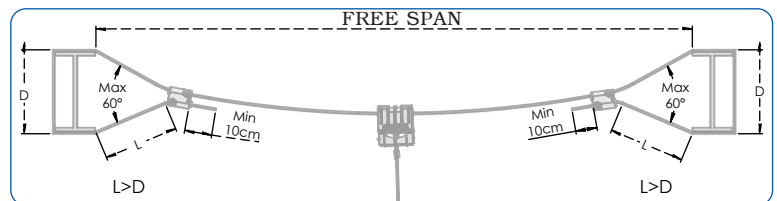
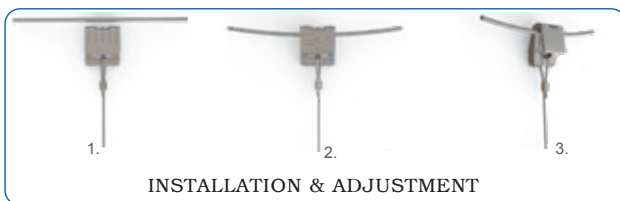
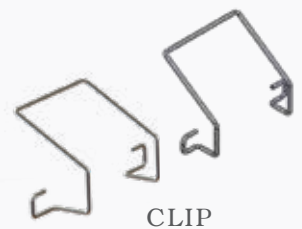

Swivel Eyelet



A swivel eyelet works in seismic bracing systems by providing a flexible and secure connection between the non-structural equipment and the structural equipment's.

A seismic bracing system consists of cables that are attached to the equipment and the beams, or girders using swivel eyelets fittings and brackets. It allows the cable to rotate and adjust to the angle and direction of the seismic force.

Some features of swivel eyelet are:

- It has a high load capacity and can handle side loads up to 90 degrees.
- It is made of alloy steel or pre-crimped wire and can be galvanized or plated to resist corrosion.
- It has a metric or UNC thread and can be easily installed or removed with the tool.
- It can be used with wire ropes, in different diameters/sizes.

Different Angles For Usages

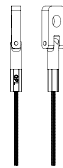

It can be use as straight

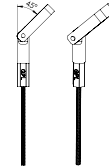

It can be use at 45°

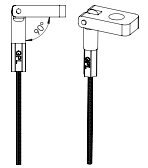

It can be use at 90°

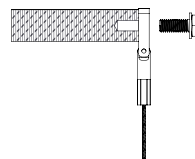

EYELET 45°, 90° & 180°

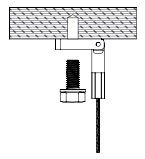
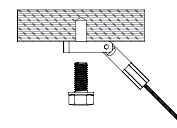

Product Details

Description: - Swivel Eyelet
 Model: - GPA-199/181/173/179/157
 Material: - Steel
 Coating: - Zinc

Recommended wire with safe working load:-

- 1.5mm – 30kg
- 2.0mm – 50kg
- 2.4mm – 70kg
- 3.2mm – 113kg
- 5.0mm – 300kg

Corner Protector

GPL Corner Protectors can be used with steel rope wire for the safety of Duct. These corner protectors will cushion the wire to be tightened to its maximum tension without damaging the product.

Each Corner Protector is constructed from specially formulated resin, which gives high impact resistance, excellent stiffness, toughness, and semi closed ribbed to hold the wire firmly in place during fitting or usage.



Details:

- Material: - Polypropylene Copolymer
- Color: - Navy Blue
- Unit Weight: - 12gms
- Dimension: - 50x50x50mm
- Suitable for upto 6 mm wire rope.

Polypropylene Copolymer (**PPC**) offers a great combination of physical, chemical, mechanical, thermal, and electrical properties, with a good strength to weight ratio.

It is superior when it comes to working temperature and tensile strength. It is lightweight, resistant to staining, and does not absorb moisture. It has excellent resistance to acids, alkalis, organic solvents, and degreasing agents. It is also tough, heat-resistant, and semi-rigid, making it ideal for use with hot liquids or gases. It's hard, smooth and the surface also makes it ideal for use in areas where bacteria build up is a concern. Polypropylene copolymer has high impact strength and is durable. It is also crack resistant.

PPC is very versatile. Its lower rigidity is ideal for use in automotive tanks to prevent cracking from road vibration, and orthotic devices. It can also be used for applications that require good chemical resistance, or **FDA** compliance.

Ferrule Loop

Ferrule Loop

Wire rope crimped with ferrule for loop making



Function:

Recommended for the suspension of HVAC, electrical and mechanical services

Applications:

Purlins, Beams, Roof, Trusses and other accessible building features

Technical Data:

- SMACNA compliance - all products carry a 5:1 safety factor
- As per UL 1598, & 2239 CSA C22.2 No.250.0-08
- Tested & Certified by TUV Nord.

Material Specifications

Ferrule Aluminium

Wire Rope Steel Galvanized

Installation

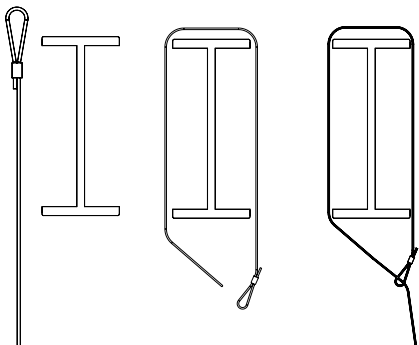

Application



Wire Diameter	1.5 mm	2 mm	3.2 mm	5 mm
Safety Factor	5:1	5:1	5:1	5:1
Safe Working Load (Kg)	Up to 30	Up to 50	Up to 113	Up to 300

Note: The correct gripper and wire rope combination should be used to ensure desired minimum safe working loads.

Stud

Stud

Wire rope crimped with M6, M8 and M10 stud



Y-fit Stud

Wire rope crimped with ferrule and M6, M8 and M10 stud



Function:

Recommended for the suspension of HVAC, electrical and mechanical services (For indoor & stationary setting).

Applications:

Concrete ceilings, metal decking and pressed metal brackets (with nuts)

Technical Data:

- SMACNA compliance - all products carry a 5:1 safety factor
- As per UL 1598, & 2239 CSA C22.2 No.250.0-08
- Tested & Certified by TUV Nord.

Material Specifications

Stud	Steel
Wire Rope	Steel Galvanized
Ferrule	Aluminium

Installation

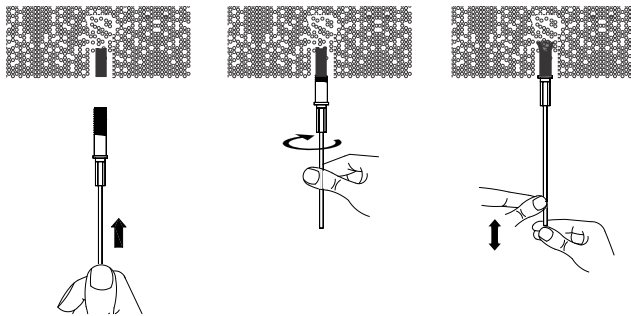

Application

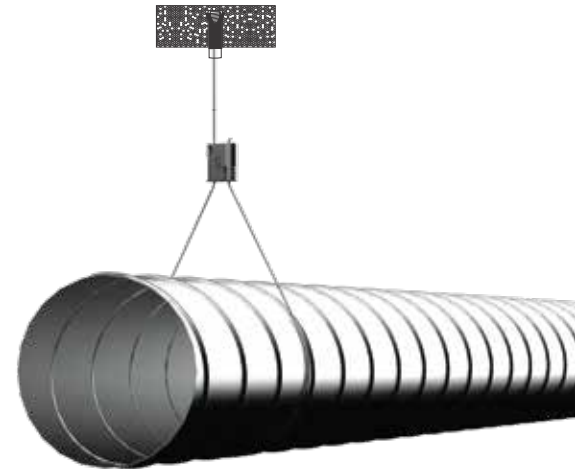

Thread	M6	M8	M8	M10
Wire Diameter	1.5 mm	2 mm	3.2 mm	5 mm
Safety Factor	5:1	5:1	5:1	5:1
Safe Working Load (Kg)	Up to 30	Up to 50	Up to 113	Up to 300

Note: The correct gripper and wire rope combination should be used to ensure desired minimum safe working loads.

Snaphook

Snaphook

Wire rope crimped with snaphook



Y-fit Snaphook

Wire rope crimped with snaphook

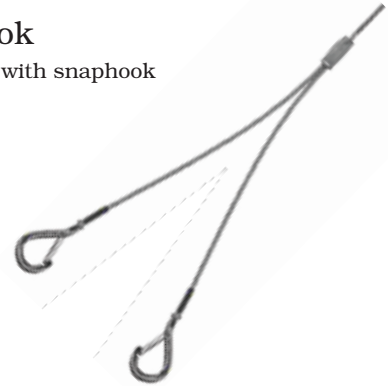

Function:

Recommended for the suspension of HVAC, electrical and mechanical services (For indoor & stationary setting).

Applications:

Suitable for use on cable trays etc.

Technical Data:

- SMACNA compliance - all products carry a 5:1 safety factor
- As per UL 1598, & 2239 CSA C22.2 No.250.0-08
- Tested & Certified by TUV Nord.

Material Specifications

Hook	Steel
Wire Rope	Steel Galvanized
Ferrule	Aluminium

Installation

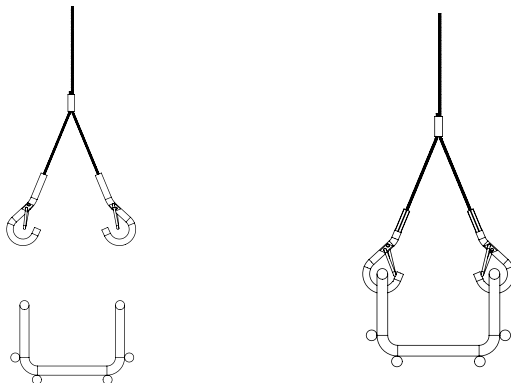

Application

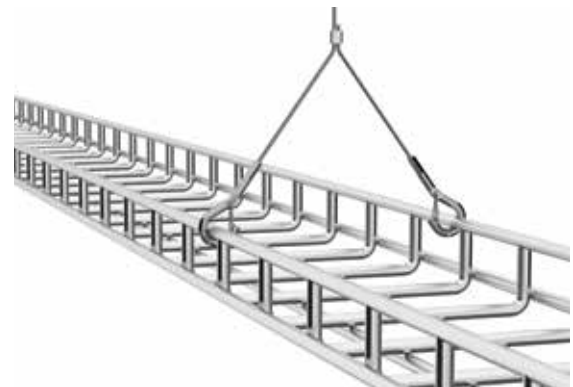

Wire Diameter	1.5 mm	2 mm	3.2 mm
Safety Factor	5:1	5:1	5:1
Safe Working Load (Kg)	Up to 30	Up to 50	Up to 113

Note: The correct gripper and wire rope combination should be used to ensure desired minimum safe working loads.

EyeBolt

EYE Bolt

Eyeloop wire rope crimped with M6, M8, M10 eyebolt



Y-fit Eyebolt

Eyeloop wire rope crimped with M6, M8, M10 eyebolt

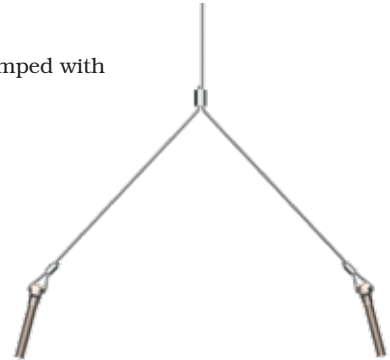

Function:

Recommended for the suspension of HVAC, electrical and mechanical services

Applications:

Suitable for concrete ceiling, metal decking and pressed metal brackets.

Technical Data:

- SMACNA compliance - all products carry a 5:1 safety factor
- As per UL 1598, & 2239 CSA C22.2 No.250.0-08
- Tested & Certified by TUV Nord.

Material Specifications

Eye Bolt	Steel
Wire Rope	Steel Galvanized
Ferrule	Aluminium

Installation

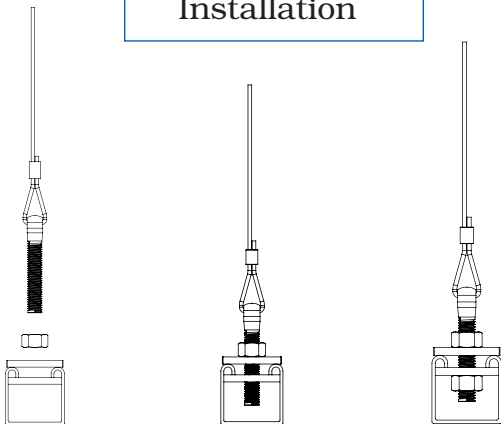

Application

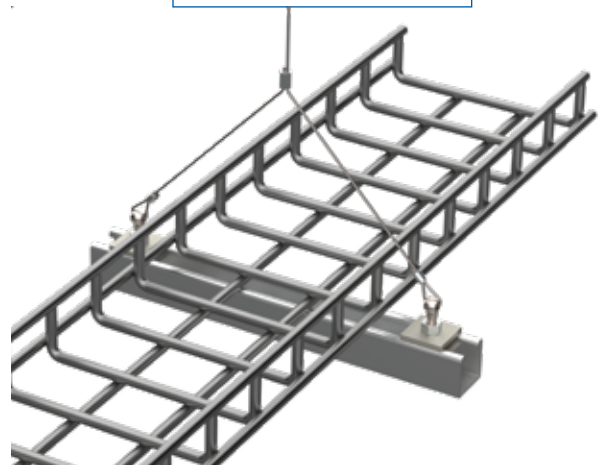

Thread	M6	M8	M8	M10
Wire Diameter	1.5 mm	2 mm	3.2 mm	5 mm
Safety Factor	5:1	5:1	5:1	5:1
Safe Working Load (Kg)	Up to 30	Up to 50	Up to 113	Up to 300

Note: The correct gripper and wire rope combination should be used to ensure desired minimum safe working loads.

Wire Rope

GPL Wire ropes are built up from individual wires. The most common are mild steel (Galvanized) and stainless steel. A number of wires together form a strand, and several strands will be twisted together to form a rope. Characteristics like fatigue resistance and resistance to abrasion are directly affected by the design of strands.

GPWS offers Wire Ropes in various thicknesses & in customized lengths.

- Customized wire rope spools can be supplied.
- Stainless steel wire rope spools can be supplied
- Remove prefix -GW and add prefix - SS in GPL code for stainless steel cables



S.No.	Material	GPL Code	Cross Section	Thickness			Length	
				Inch	Cm	Mm	Ft	Mtr
1	Galvanized	GW16300	7x7	1/16"	1.6	1000	300	
2	Galvanized	GW20300	7x7	5/64"	2.0	1000	300	
3	Galvanized	GW24150	7x7	3/32"	2.4	500	150	
4	Galvanized	GW32150	7x7	1/8"	3.2	500	150	
5	Galvanized	GW40150	7x7	5/32"	4.0	500	150	
6	Galvanized	GW50150	7x7	3/16"	5.0	500	150	

Note: This is a standard load chart but different product combinations offer different safe working loads. Please speak to GPL expert for any clarification.

WIRE CROSS SECTION

7x7



7x19

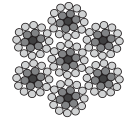

Minimum Working Loads (MSWL)

- Mentioned loads are achieved using GPL gripper and GPL cable only
- The 5:1 MSWL is tested and approved by TUV Nord group on specific products
- Loop gripper load is achieved when used vertically in a looped configuration
- Values in **BLUE** are in kilograms and values in **RED** are in pounds

Cable Diameter		Safe Working Load (KGS / LBS)	
		Galvanised Cable	
mm	Inch Fraction	Loop Grippers	Single Grippers
1.6	1/16"	30 / 66	25 / 55
2.0	5/64"	50 / 110	45 / 99
2.4	3/32"	70 / 154	60 / 132
3.2	1/8"	113 / 249	100 / 220
4.0	5/32"	160 / 352	120 / 264
5.0	3/16"	300 / 661	250 / 551

Note: This is a standard load chart but different product combinations offer different safe working loads. Please speak to GPL expert for any clarification.

Warnings:

- Use only GPL specified wire construction to get the desired result.
- Do not exceed the safe working load of the product.
- Do not use covered / insulated cable.
- Do not apply paint or other coating.
- Do not apply lubricant.
- This product is not recommended for lifting loads.
- Remove damaged cable end prior to inserting into the gripper.
- Do not use it in chlorinated atmospheres.
- Recommended for use in dry locations only.
- Recommended for static load applications only.

Prestigious Installations

FMCG



EDU TECH



Healthcare / Agri / Pharma



Automotive



IT / BPO / E-Com / Data Centre



Manufacturing



Lighting Company





(The Golden Peacock Group)

List of Projects

3M India Limited - Bengaluru
ABB Office - Bangalore
Accenture - Bengaluru
Aditya Birla Group company - Bhuvaneshwar
Aether Energy - Bangalore
AIG Hospital - Hyderabad
AIIMS - Bilaspur, Jhajar, NCR
Akamai - Bengaluru
All Kind - Baddi, Himanchal
All State - Bangalore
Allergan - Bangalore
Alliance - Bangalore
Alstom - Madepur, Bihar
Amazon - Bangalore, Hyderabad
Amazon Development Services - Hyderabad
American School - Chennai
ANSR - Bangalore
Aquarelle India Pvt Ltd - Bengaluru
Asahi GlassBawal, - Haryana
Ascendus - Bangalore
Asian Paints - Mysore
Astral Ahmedabad, - Gujarat
ATG TyresVizag
Athena - Bangalore
Atlassian - Bangalore
Autodesk - Bangalore
Bank Note Press Devas, - Indore
Baxter - Bangalore
Bekart Industries - Ranjangaon, MH
BIAL - Bangalore
BIG BASKET - Bengaluru
Bikano - Rajasthan
Birla Soft - Bangalore
Blue Neem - Bangalore
Boeing Tower - Hyderabad
Brigade Rubix - Bangalore
Buildmet Textile - Dabuspeth
Cadents - Bangalore
Ceat - Nagpur
Co Works - Bangalore
Coca Cola - Pune
Cognizant - Pune
Cohecity - Bangalore
Collebra - Bangalore
Conduent - Bangalore
Covance - Bangalore
CSGI - Bengaluru
Cynchronous - Hyderabad
Dabur - Pithampur
DDFS Store, - IGI AirportDelhi, NCR
DDFS Store, - IGI AirportDelhi, NCR
Decathlon - Bangalore, Vijayawada
Dell Technology Services - Bagmane WTC
Dellyte - Bangalore
Design Tree - Mundra
DHL Office - Chennai
Eagle View Print - Bangalore
Eastman - Bangalore
EC Works - Bangalore
ECOTRON - Ambala
Emerald Bay - NCR
Epam Systems Pvt Ltd - Hyderabad
EPIQ - Hyderabad
Epsilon - Bangalore
ETV - Bangalore
Evergent - Bangalore
Facebook - Bangalore

GMR Airport - Hyderabad
Graphic EraDehradun, - Uttarakhand
GSK - Hyderabad
GTV - Bangalore
Havells India - NCR
Henkel - Pune
Himadsingka Textile Hassan, - Karnataka
Hitachi - Bangalore
HIVE - Bangalore
Honda - G.Noida, U.P
Honeywell - Pune
HSBC - Bangalore
IAS Officers Association - Bangalore
ICE - Hyderabad
Iffco Phulpur, - Aonola
Indian Express - Bangalore
Informatica - Hyderabad
Infosys Limited - Hyderabad
INOX - Mumbai
Instakart - Pune
Intas Ahmedabad, - Gujarat
Isprout - Hyderabad
IT Space - Hyderabad
ITC Green Centre - Bengaluru
ITC Windsor Manor - Bangalore
JD club house - NCR
JK Tyres - Morena
JLL - Hyderabad
Jockey - Karnataka
JPMC - Bangalore
JWI Devanahalli - Bangalore
Karatia Snack PelletsRajkot, - Gujarat
Kennametal - Bangalore
Key Stone - Kerala
KIA Motors - Bangalore
Legato - Bengaluru & Hyderabad
lenskart - Bhiwadi
Lighting Technologies - Bengaluru
Linkedin - Bangalore
Log Me Inn - Bangalore
Loyal Textiles Erode, - TamilNadu
MAERSK - Bangalore
MAG INDIA - Bangalore
MASHREQ - Bangalore
McAfee - Bangalore
Medanta Hospital - Lucknow, U.P
Micron Technology - Hyderabad
Minda Factory - Ahmedabad, NCR
Molex - Bangalore
Motherson Corporate Tower - NCR
MRF Tyres Arrakonam - Chennai
Mylan Laboratories - Indore, M.P
Myntra - Bilaspur (HP), Bangalore, Mumbai
Netapp - Bengaluru
Oath - Hyderabad
Oeven - Hyderabad
ONGC - Mumbai
Oracle - Bangalore
Otis - Bangalore
Pannaga - Bangalore
Pantaloons - Bangalore
Parle - Bangalore
Pay Pal - Bangalore
Philips Lighting - NCR
PRD HALL DELHIDelhi, NCR
Prestige - Bangalore
Proclaim - Aurangabad

Electronics Technology ipl -Chennai
Flipkart - PAN INDIA
Friday Film - Mumbai
GAR - Hyderabad
Geetham Ventures - Bengaluru
General Industrial Control - Pune
Global Logic - Bangalore
PVR Cinemas - Bangalore
Qualcomm - Hyderabad
Ralson - Indore
RB - Hyderabad
Renault Nissan Automotive Oragadam, - Chennai
RMZ Galleria - Bangalore
Rocket Software, - Karle Town Centre Bengaluru
Rubrik - Hyderabad
Rudraksh Detergents - Baroda
Sabie Innovative Plast - Vadodara, Gujarat
Sakata Factory - Bangalore
SAP Labs - Bangalore
SARI - Jaipur
science City aquarium - Mumbai
SEHUNK - Bangalore
Service Now - Hyderabad
Simply Works / Google - Hyderabad
Sixt R&D India Pvt Ltd Cessna Business Park, - Bengaluru
SK Convention Hall - Bangalore
Smith and Sharks - Mumbai
Southern Land - Chennai
Space Matrix - Bangalore
Sundaram Clyton Ltd Oragadam, - Chennai
Swiggy - Bangalore
Synchron - Bangalore
Synichro - Bangalore
TAJ SATS - Bengaluru
Target - Bangalore
TDIM - Hyderabad
Telestra - Hyderabad
Thomson Reuters - Hyderabad
Thryve - Bangalore
Toyota - Bangalore
Troikaa - Ahmedabad, Gujarat
Uber - Bengaluru
Udaan - Karnataka, Nagpur, Bingipura, Chennai, Hosur, Makali
UST - Hosur
Vandematharam - Bangalore
Verizon - Chennai, Hyderabad
Volkswagen - Bangalore
Walmart India Pvt Ltd Karimnagar/Kurnool/Nizamabad, Warangal
We works - Bangalore, NCR
Weg Motors Hosur
Wells Fargo - Bangalore
Wipro - Mumbai
Wonder - WorksNoida, U.P
Zinga - Bangalore

GPL EXPORTS WORLDWIDE



January, 2025



ISO 9001:2015



GPL TECHNICAL SOLUTIONS PVT.LTD.

Registered Office : D-82, Hosiery Complex,
Phase II Extension, Noida - 201305, India
Phone : 0120-4720251/54, mktg@goldenpeacock.com

GOLDEN PEACOCK OVERSEAS LTD.

Corporate Office : 20A, NSEZ Noida-201305,
UP, India Phone : 0120-4720251/54,
Phone : 0120-4720251/54, mktg@goldenpeacock.com